Faculty of Mathematical Sciences



University of Twente
The Netherlands

P.O. Box 217
7500 AE Enschede
The Netherlands

Phone: +31-53-4893400

Fax: +31-53-4893114

Email: memo@math.utwente.nl

www.math.utwente.nl/publications

MEMORANDUM No. 1658

Utterance paths

L. ZHANG¹ AND C. HOEDE

NOVEMBER, 2002

ISSN 0169-2690

¹Department of Computer Sciences, Northwest University, Xi'an, Shaanxi 710079, China

UTTERANCE PATHS

L. ZHANG

Department of Computer Sciences

Northwest University

Xi'an, Shaanxi 710069, China

C. HOEDE

Department of Applied Mathematics

University of Twente

P.O.Box 217

7500AE Enschede, The Netherlands

Abstract

In this paper the concept of utterance path is investigated. In the theory of knowledge graphs sentences are represented by so-called sentence graphs. The sentence graph of a sentence can be obtained by structural parsing of the sentence. Here we study the problem of determining rules for uttering the sentence graph. Given a sentence graph there are usually several ways how such a graph can be brought under words, i.e. can be uttered. The sentences arising from these ways of uttering consist of words occurring in the sentence graph in a specific order. Languages differ in the way the words occurring in the sentence are ordered. We investigate several sentences both in English and in Chinese.

Key Words: knowledge graph, sentence graph, utterance path.

AMS Subject Classifications: 05C99, 68F99

1 Introduction

We refer to the paper of Hoede and Zhang [Hoede & Zhang, 2001b] for general background information on *structural parsing*, only recalling the most essential things here.

In the theory of knowledge graphs, words are represented by two word graphs, a syntactic word graph and a semantic word graph. The syntactic word graph describes how a word can function syntactically with respect to other words. The semantic word graph describes the meaning of the word.

The vertices of the graphs are called *tokens* and are represented by the symbol \ddot{y} . These tokens are representing concepts that can be labeled and that can be related to other concepts.

The labeling is done by words. As an example we consider the graph consisting of three tokens related by CAU-relations, arcs with the label CAU, which stands for “causal”, given in Figure 1.

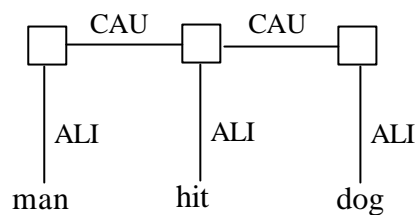

Figure 1. Sentence graph for “man hit(s) dog”.

We see that the three words are functioning as labels of the three tokens and that these labels are connected to the tokens by arcs of the type ALI. This representation is used to indicate types of concepts. A second way of labeling is by means of a directed EQU-relation between word and token. This is used to indicate instantiation. As an example, let Pluto be a specific dog and Peter be a specific man. Then we obtain Figure 2.

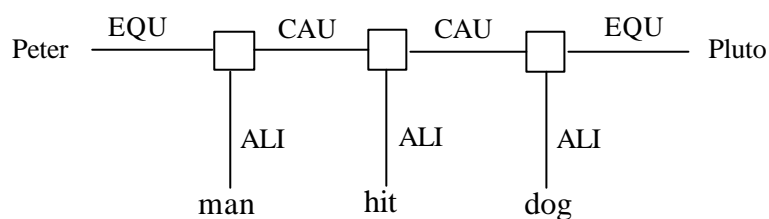

Figure 2. Sentence graph for “(The) man Peter hit(s) (the) dog Pluto”.

For the relations between tokens sofar eight types have been introduced, see the paper referred to. They are called EQU, SUB, ALI, DIS, ORD, CAU, PAR and SKO, and describe respectively equality, subset relation, alikeness, disparateness, ordering, causality, attribution and informational dependency.

Next to these eight binary relations there are 4 so-called *frames*, the FPAR, the NEG(PAR), the POS(PAR) and the NEC(PAR) frame. These frames can be used to describe logic, see van den Berg [Berg, 1993]. Particularly important is the FPAR-frame, as concepts are seen as subtypes of a huge *mind graph*. The brain is supposed to make a representation of perceptions by creating a graph, consisting in the first instance of tokens, due to perception, and binary relations between them. *Words*

come in when a subgraph of the mind graph is “framed and named”. The subgraph is a concept, and can hence be represented by a token, that may now be labeled. As an example we can consider a very simple graph like given in Figure 3.

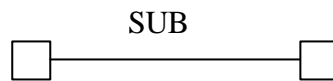

Figure 3. Word graph for the word “in”.

This graph consists of two concepts and expresses that one is part of the other, like a set can be a SUB-set of another set. (Note the use of the letters S, U, B in subset).

If this graph is considered, no word is still mentioned or plays a role. The mind is supposed to be able to recognize a SUB-relationship. Once this subgraph of the mind graph is focused upon, the problem of naming this graph comes forward. In English we would use the word “in” to label the graph in Figure 3. In Chinese a dictionary shows fifteen different words for expressing what in English is expressed by the use of the word “in”, see [Hoede & Li, 1996]. For each of these fifteen different words, different word graphs were found.

Let us now consider a sentence like “man hit(s) dog”. The problem to establish Figure 1 is to construct the sentence graph from the word graphs for each of these occurring words. This has led to the development of structural parsing theory. Suppose that the sentence graph is given. Then we may ask what the sentence looks like that utters the situation expressed by the graph. There are $3! = 6$ ways to utter the graph. We might say:

- man hit dog
- man dog hit
- hit man dog
- hit dog man
- dog hit man
- dog man hit .

In English, and in Chinese, the first *utterance path* is used. However, in other languages other orderings, other utterance paths, occur. In Japanese the verb is usually put at the end as in the second and sixth way to utter the graph. The six orderings are usually described by the syntactic function of the words, “man” is the subject (S), “hit” is the verb (V) and “dog” is the object (O) grammatically. English and Chinese are therefore often called SVO-languages, as that ordering has developed for these two languages. We want to stress that, therefore, our considerations about utterance paths are language dependent.

The graph in Figure 1 must, in English, be uttered as “man hit(s) dog”. This sentence starts with a noun. Any grammar, in English, with production rules, starts by the rule $S \rightarrow NP VP$, where S stands for “sentence”, NP for “noun phrase” and VP for “verb phrase”. In our simple example the NP is “man” and the VP is “hit(s) dog”. Uttering the

graph in Figure 1 should therefore start with “the noun in the noun phrase”, which is, of course, “man”. But how can the noun phrase be recognized in the graph?

There are various ways to find out whether a word is a noun. First, a lexicon of words may explicitly say that “man” is a noun, as is “dog”. Second, we could use the method described by Radford [Radford, 1988], who discussed test sentences like:

—— can be a pain in the neck.

If a word can be placed in the slot indicated by —— to give a sentence that makes sense, the word is a noun. Indeed both “man” and “dog” pass this test, but hit(s) does not. The problem with this method is that the outcome comes from the human being, who has to decide whether the sentence makes sense. We therefore should point out that there is a third way to find out the word type involved here, *from the structure of the graph*.

A token with an incoming and an outgoing CAU-arc can only be a transitive verb, as only verbs are represented with the help of CAU-arcs. This makes hit(s) a verb. An intransitive verb would only have an incoming CAU-arc. The tokens from which and to which the CAU-arcs are coming respectively going, must be labeled by words that are nouns. This too is due to the way word graphs are used, see the syntactic and semantic word graphs in [Hoede & Zhang, 2001a].

For our utterance problem we now know how to proceed. Find the verb, looking at the CAU-arcs, and find the noun from which there is a CAU-arc towards that verb. We find “man”. Then, because of the rule $S \rightarrow NP VP$, start by uttering “man”. As English is a SVO-language we know that now first “hit(s)” and finally “dog” has to be uttered.

In the graph we see that we follow the path from the token “man” to the token “dog” via the token “hit(s)”. The utterance path has been found for our simple example sentence graph. Note that the ordering of the CAU-arcs, with our rule for uttering, does not lead to “dog hit(s) man”.

It is, however, not only the syntactic interrelation of words that plays a role. Also semantic concepts play an important role. To make our point clear, let us consider an example given in [Radford, 1988]. He mentions that in Serbocroatian the four words {Peter, read, book, today} may be put in any of the $4! = 24$ possible orderings without changing the meaning and, what is particularly interesting, all these utterance “paths” are allowed, i.e. are considered to be grammatical.

What we meet here is a phenomenon, that does not occur in English or Chinese. There only 4 or 5 of the 24 orderings are good. For example

* Peter today book reads.

is not allowed in English. Such non-grammatical sentences are indicated with a star: *.

We can give an explanation why the 24 utterance paths are equally well possible. The sentence graph is the same for all these 24 sentence and is given in Figure 4.

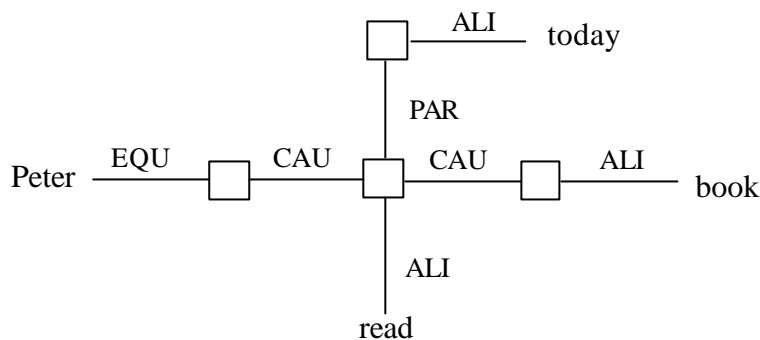

Figure 4. Sentence graph with the word set {Peter, read, book, today}.

The solution is that “Peter” cannot be read and “book” cannot read, which puts these pronoun and noun in the position of subject and object, purely on semantic grounds. In the case of “man hit(s) dog”, exchanging the positions of “man” and “dog” gave a semantically completely different sentence. But here exchanging the position of “Peter” and “book” does not have any consequence, for the meaning of the sentence, as the person reading or hearing the four words reconstructs the sentence graph in a unique way. Also the word “today” can only be attached to the verb “read”.

We conclude that there is, in this particular case of Serbocroatian, hardly any utterance rule. Just utter the four words, in any order.

2 Utterance Paths and Generative Grammar

A sentence is a linearly ordered set of words. In traditional parsing a parse tree is generated following grammar rules. Radford [Radford, 1988] calls the parse tree a *phrase marker*. In the parse tree phrases are usually easily recognized as subtrees.

Let us consider the sentence “Peter read(s) (the) book today”, again. In order to discuss the relationship between utterance path and generative grammar, let us recall that there is just one sentence graph, namely the one given in Figure 4. This sentence graph is the meaning of any ordering of the four words that is admissible, i.e. can be generated by the grammar. We may generate one example sentence by the rules:

S ? NP VP

NP ? PN

VP ? V AP

V ? V N

AP ? adv

PN ? Peter

V ? Read
 N ? Book
 adv ? today .

The resulting parse tree is:

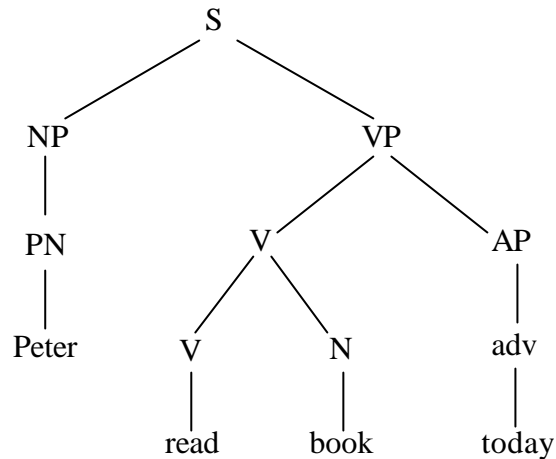

Figure 5 Parse tree for one particular uttering

It is clear that, if the sentence graph is brought under words by an utterance path so that an admissible ordering, for the generative grammar, is obtained, the grammar has rules that justify the utterance path chosen. As a very simple example we compare the utterance “the book” with * “book the”. In English the determiner “the” must be uttered before the noun, and there is a grammar rule N ? det N, not a rule N ? N det.

So we see that utterance paths must follow the rules of the generative grammar of the particular language considered. Suppose now that there is a language ? in which there is only one way to make a sentence out of the four words {Peter, read, book, today}, and let this be, for example, the sentence “Peter read(s) (the) book today”. Then we have one sentence graph, Figure 4, but in Serbocroatian there are 24 uttering possibilities, in English or Chinese only a handful, 4 or 5, and in ? there is only one possibility.

Note that these numbers depend on the grammars for these languages and are numbers of phrase markers/parse trees that correspond to sentences with identical meaning.

The main conclusion for the problem of utterance paths for sentence graphs is that it is very difficult to give general rules for bringing a sentence graph under words.

In the language ? there is no flexibility at all. The ordering of the words is precisely prescribed. ? is a typical SVO-language. In Serbocroatian there is high flexibility. The ordering of the uttered words is not dependent on the structure of the sentence graph. Yet it may turn out that some of the 24 possible utterings of the sentence graph are more often used than others. It is not unlikely, for a European language, that SVO orderings are more often used.

To enable a generative grammar to generate all 24 possible orderings of the four words,

it must have many different production rules. Language ? only allows one ordering and must therefore have only a restricted set of production rules. There is a corresponding difference in the numbers of possible utterance paths for the sentence graph.

On the other hand we may say that the number of utterance *rules* in Serbocroatian, for this example sentence, is very small;

- “Utter some word”
- “Let a word be followed by a next word”.

In ? the number of utterance rules is large.

- “Start with this specific word”.
- “Then let it be followed by that specific word”, etc.

There are $n!$ permutations of n words. If all are admissible, for some grammar, then, again, the number of rules for uttering a sentence consisting of these n words is very small; 2. If only one permutation is admissible the number of rules is large; n .

3 Uttering an Extended Example Sentence Graph

We have seen in the last section that the number of ways to produce a sentence, given a unique sentence graph, depends strongly on the language used. We will therefore not focus on general rules, but just investigate whether in English or Chinese patterns can be found in the way admissible utterance paths reflect the structure of the graph. Figure 1, can only be uttered as “man hit(s) dog”, using only these three words, following the SVO-structure of sentences in English. We start with the token for the subject noun in the graph and follow the path determined by the CAU-arcs. This example is now extended to the following sentence:

“The mean tall man hit(s) the poor small dog in the garden with a very big stick”.

Next to the verb “hit” there are the NPs “the mean tall man” and “the poor small dog”, and the APs “in the garden” and “with a very big stick”. We want to see in which order these phrases can be uttered.

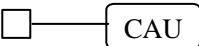
First we remark that the graph in Figure 1 can also be uttered as “dog **is** hit **by** man”. When uttered this way, the “be” frame that can be considered to be present around any sentence graph, and therefore omitted, is now explicitly mentioned. As the object “dog” is mentioned first, thus suggesting a CAU-arc going out from this token, the fact that it is the “man” who is the agent is expressed by the incoming CAU-arc of “hit”. The word graph for “by” can be taken to be: . Something that is doing the act, that is expressed by the verb that must follow the outgoing arc, can be brought under words as “by (something)”. This extends our possibilities to order the phrases together with the central verb. However, the verb has to be sandwiched by the two NPs also in this way of uttering. The two APs can occur on any of the eight phrases indicated by the

symbol \square in:

$\square\square$ man $\square\square$ hit $\square\square$ dog $\square\square$.

In written language we will use commas and in spoken language pauses will be taken. For example one might write “In the garden the mean tall man, with a very big stick, hit the poor small dog.” Or: “The mean tall man, with a very big stick, hit(s) the poor small dog, in the garden.” Or: “The mean tall man hit(s) the poor small dog, in the garden, with a very big stick.”

There is high flexibility in uttering the four phrases, apart from the positioning of the two NPs with respect to the verb. Like for the example considered in Section 2, this can be understood on semantical grounds. The APs are adverbial phrases for the verb. Before considering the phrases themselves let us give the complete sentence graph in Figure 6.

Note that “the” with word graph \square —^{EQU}— \square (3 times) and “a” with word graph element \square —^{ALI}— \square —^{PAR}— \square —^{ALI}—set are not mentioned in the graph as we wanted to avoid frames in the figure. Also the prepositions “with” with word graph \square —^{PAR}— \square and “in” with the word graph \square —^{SUB}— \square are not mentioned, for the same reason.

The four phrases correspond to four subgraphs of the sentence graph, that all four have tree structure. The two NPs have corresponding subgraphs that are identical in structure. The determiner has to be uttered first, the two adjectives can then be uttered in arbitrary order, but before the head noun, unless commas are allowed, as then one might write “the dog, small, poor,”. The AP “with a very big stick” shows an extra feature. The connecting preposition is uttered first and then the determiner. But then the subgraph corresponding to “very big stick” shows a clear utterance path, starting as the outermost token for “very” via that for “big” to that for “stick”. Its arcs are of the PAR-type. Let us call the subgraph induced by the two CAU-arcs the main structure. Then we can say that, in English, the main structure follows the SVO pattern. The phrases are extensions of the head nouns or the verb. We already saw how the corresponding subgraphs are uttered. Most importantly, we must remark that these subgraphs are uttered “in one piece”. One cannot utter one of its constituent words while uttering another subgraph. These subgraphs are phrases that correspond to the chunks that we considered in [Hoede & Zhang, 2001b]. The rather arbitrary order in which these phrases can be uttered, when pauses are used in spoken language, is possible due to the fact that the syntactic functions of the APs is fixed; they attach to the verb. We recall that chunks were introduced, by pointing out that people tend to make pauses in speaking.

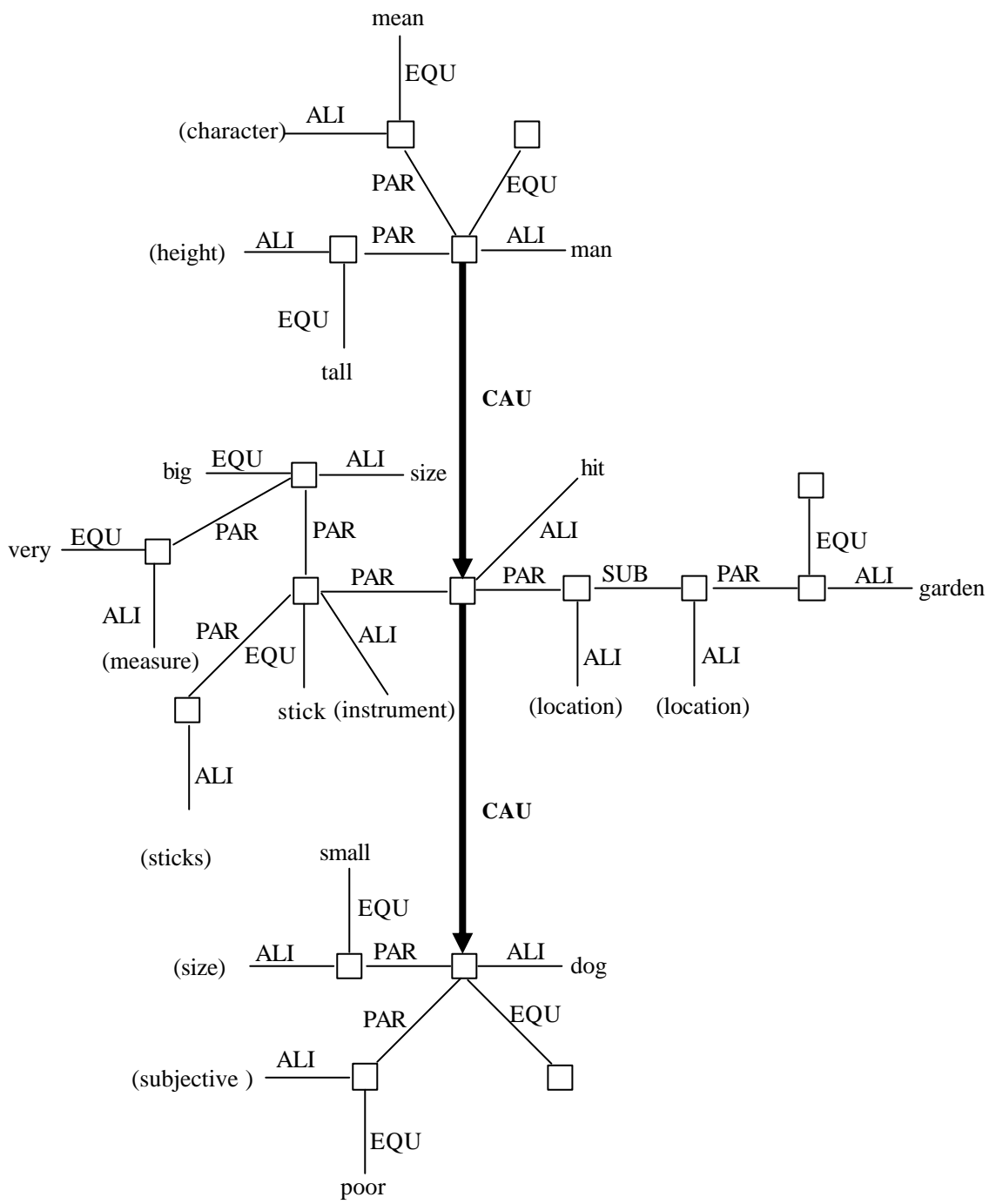

Figure 6. Sentence graph for the extended example sentence.
Words between parentheses do not occur.

4 Uttering a Sentence Graph with Reference Words

In language many times reference words are used. The most common word is the determiner “the”, which refers to something in the context of the conversation. In “man hits dog”, this reference has been omitted, but in “the man hits a dog” we have reference to some determined man, whereas the article “a” does not refer to a particular dog. Words like “this”, “that”, “these”, “those”, “who”, “which” and pronouns like “he”, “she”, “him”, “her”, “us”, etc. serve to avoid repetition of already known or mentioned constituent words in a discussion.

In [Hoede & Zhang, 2001b] we considered the example sentence “The volcano, that lies in Alaska, 130 kilometers from Anchorage, erupted in 1992.” This sentence could also be uttered as “The volcano, that erupted in 1992, lies in Alaska, 130 kilometers from Anchorage.” In both cases the word “that” refers to the volcano and is used for economic reasons.

The basic structure of the sentence graph is

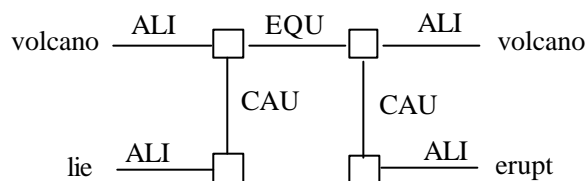

Figure 7. A subject for two verbs .

In uttering one could cope with the occurrence of two verbs by uttering two sentences, “The volcano lies, etc.” and “The (same) volcano erupted, etc.”. However, the repetition of “The volcano” can be avoided by referring to the once mentioned volcano by means of the word “that”. Due to the symmetry of the figure we can choose either of the two verbs for the main utterance path and utter the other verb in the subsentence containing “that”, on a side line so to say.

In a sentence like “He hit the dog, that hated him”, we have multiple use of reference. “He”, “the”, “that” and “him” all have a reference function. “He” refers to some man, “the” to a particular dog, “that” to that dog and “him” to “he”. In the sentence graph these references should be recognizable. As the reference is described by the EQU-link, we have a graph like Figure 8.

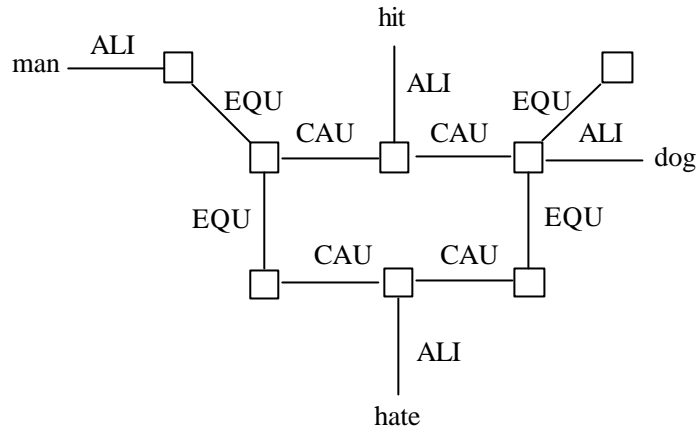

Figure 8. Sentence graph for “He hit the dog, that hated him”.

Note that we could have contracted two of the EQU-links, the two vertical ones, but then the reference words would not have been so clear. We essentially have a graph for two sentences; “He hit the dog” and “The dog hated him”, where we omit a discussion of the tenses.

Also note that the subgraph $\text{man} \xrightarrow{\text{ALI}} \square \xrightarrow{\text{EQU}} \square$ is given as the word graph for “he”, which is considered to have the meaning “something like a man, to whom is referred”.

If a sentence graph contains more verbs, we see that we need not have a tree structure. Before uttering, reference links can be introduced so that the main SVO-structures are completely represented with tokens for S, V and O, here for “he hit dog” and “dog hate him”. Now the utterer can choose between cutting the graph by deleting EQU-links, while transferring all information attached to one token also to the other, or leaving the graph intact. In the first case more sentences have to be uttered, with repetition of words. In the second case reference words can be used. Once the graph has been replaced by more graphs, containing only one verb, the occurring phrases can be uttered according to rules as discussed in Section 3.

5 Uttering Graphs Containing Frames

In this section we discuss the uttering of sentences with sentence graphs that contain frames. At the same time some aspects of representing tense will be discussed. We consider an example mentioned by Radford [Radford, 1988], that reads “He might have been writing a letter”. We place “writing a letter” by “walking”. The things we want to investigate can also be discussed for the sentence “John may have been walking”.

We intend to gradually increase the complexity of the sentence in order to see how frames come into play. Both English and Chinese sentences are considered.

First we consider the very simple sentence

- John walks.
- John san4bu4.

The sentence graph is

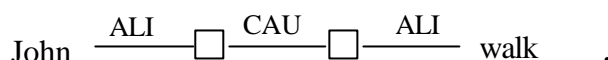

The tense, present, can be expressed by relating the time at which the act, described by the verb, is taking place to the time t_s at which the sentence is spoken. The present tense is characterized by $t_s \in [t_b, t_e]$, where the time interval $[t_b, t_e]$ denotes the time from the beginning of the act, denoted by t_b to the end of the act, denoted by t_e . In the sentence graph this leads to a graph of the following form:

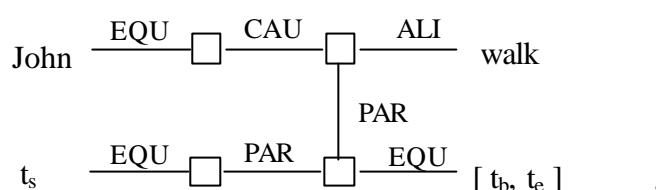

Now we consider the sentence

- John is walking.
- John zai4 san4bu4.

The change that has taken place is the use of the auxiliary verb “be”. In the sentence graph “be” is expressed by a frame. The graph now looks like

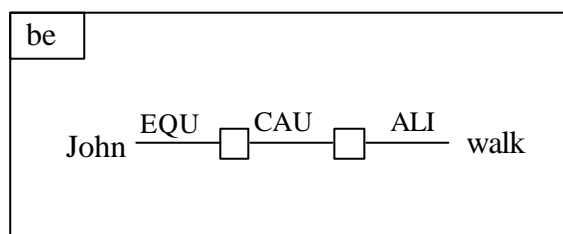

Note that there is hardly any difference in meaning. The “be” frame is put around the sentence graph of “John walk”. In Chinese “zai4” can be seen as an adverb, expressing time, namely “now”, “John now walk” is the literal translation of the Chinese sentence.

As a third sentence we consider the imperfect past tense. The sentence reads

- John walked.
- John san4bu4 le.

In the sentence graph of the first sentence only the time description changes. As the walking act has taken place in the past, but has not yet been ended for sure, we describe this by

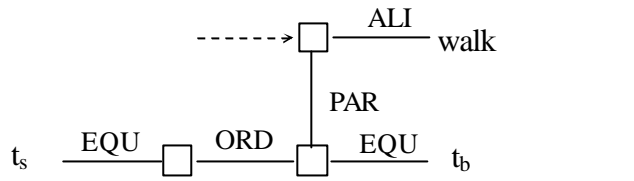

where only the essential part of the graph has been given. The ORD-relation expresses that the act began at time t_e before the time of speaking t_s .

In Chinese the use of the word “le” is quite typical.

The fourth sentence is

- John was walking (when I swam yesterday) .
- (Zuo2 tian1 wo3 you2yong3 shi2) John zai4 san4bu4.

The sentence graph is identical with that of “John is walking”, but for the description of the tense aspects by “shi2”. This is described by the graph construction used in the third sentence, to describe the imperfect tense, now attached to the “be”-frame:

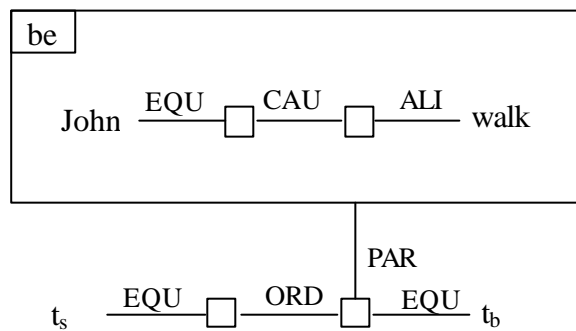

The literal translation of the Chinese sentence is “John in the past now walk”.

The fifth sentence is

- John has walked.
- John yi3jing4 san4bu4 le.

The perfect past tense is posing some problem, in English. The problem is the use of the auxiliary verb “have”. There are three merological relation types in the ontology of knowledge graphs; the FPAR-relation, describing properties, the SUB-relation, describing parts and the PAR-relation, describing attributes. We have seen, in [Hoede & Zhang, 2001a], that “have” can be interpreted as “be with”. All three merological relationships are expressed in English by use of the words “with” or “of”. If the interpretation of “have” as “be with” is taken to hold universally, then in “John has walked”, there is the problem of identifying the part of the sentence graph corresponding to the word “with”. One way of looking at the use of “have” is that “John”, after having completed the walking obtains this as a property. However, in Chinese the word “yi3jing4” expresses the completion of the walking act. This word acts as an adverb of time. So the sentence graph looks like

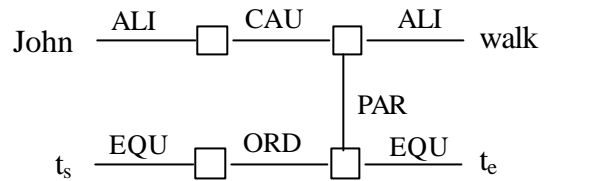

The only change that has taken place, with respect to the sentence graph of “John walked” is that t_b has been replaced by t_e . This very concisely describes that the act has indeed been completed. It looks that the use of “have” in English to describe the perfect past tense must be seen as a special linguistic development. The Chinese way of expressing the perfect past tense is more consistent with the way other tenses are expressed. The knowledge graph representation is more closely following the Chinese language, at this point.

The sixth sentence reads

- John has been walking (when I swam yesterday).
- (Zuo2 tian1 wo3 you2yong3 shi2) John yi3jing4 zai4 san4bu4 le.

Again the only change, with respect to the graph for “John was walking”, is the replacement of t_b by t_e , and consequently in Chinese the use of the word “yi3jing4” for expressing the completion.

Finally we come to the seventh sentence

- John may have been walking (when I swam yesterday).
- (Zuo2 tian1 wo3 you2yong3 shi2) John ke3neng2 yi3jing4 zai4 san4bu4 le.

The auxiliary verb “may” is expressed by a POS-frame, put around the whole sentence graph for the sentence “John has been walking”. In Chinese the word “ke3 neng2” is seen as an adverb. In fact, one might say “John possibly has been walking”. The choice for the POS-frame can be defended also by the fact that yet another way to express the sentence graph is “It is possible that John has been walking”. Note the use of the two reference words “it” and “that”.

The peculiar use of the verb “have” in English for describing the perfect past tense should also be considered against the fact that in rather related languages like Dutch or German “has been” is expressed by “is geweest” respectively “ist gewesen”. So, in those languages in stead of “have” the auxiliary verb “be” is used. This feature is completely avoided in Chinese.

6 Uttering Quantification

Let us recall the way existential quantifier and universal quantifier were expressed in knowledge graph theory. The existential quantifier is expressed by a distinct

knowledge graph. In a very simple case we may have a graph like $\square \xrightarrow{\text{ALI}} x$ which can be uttered as “something like x”. Anything stated about x can be described by a sentence graph containing x. If this statement is P(x) then the sentence graph describes P(x), an open formula in logic. If x is instantiated, for example by a, then the graph $a \xrightarrow{\text{EQU}} \square \xrightarrow{\text{ALI}} x$ can be uttered as $\exists x$, there exists an x, namely a. Combining the graph for P(x) and the instantiation we obtain a knowledge graph that can be uttered as $\exists x P(x)$, a closed formula in logic, or as “there is an x for which P(x) holds” in natural language.

The universal quantification poses some delicate and interesting problems. In the beginning of the second phase of the knowledge graph project words like all, any, every and each were considered to be expressible by the SKO-loop, see [Berg, 1993].

However, like for the fifteen different words in Chinese for the preposition “in”, in principle for the four mentioned words there should be four different word graphs. Investigating the word “dou1” in the context of uttering a given sentence graph in Chinese, various subtle differences for the words used in universal quantification came forward. In the next section we will first discuss these differences before dealing with the word “dou1”.

6.1 All, any, each and every

Let us begin with giving the description of these four words as found, e.g., in the Oxford Pocket Dictionary [Allen, 1984]. We read

- all** : 1. whole amount
 - 2. all persons concerned, everything
 - 3. *adv.*, entirely, quite
- any** : 1. one, no matter which, of several
 - 2. some, no matter how much or many or of what
- each** : every one of two or more persons or things, regarded separately
- every**: 1. each single
 - 2. all possible.

Before discussing these entries in the dictionary, let us consider the Chinese translation possibilities. Words used in Chinese in universal quantification are

- dou1** : *adv.* all
- suo3 you3 de** : all
- ren4 yi4** : arbitrary
- ge4 ge4** : 1. each, every

2. one by one, separately

mei3 ge4 : every, each, per.

The translations are as found in A Modern Chinese-English Dictionary [Ce, 1988]. One interesting remark is still to be made first. The logical statement $\forall x P(x)$ is expressed in Chinese as “ren4 yi4 x P(x)” or as “sou3 you3 x P(x)”. In English we can say “For all x P(x)” and “For any x P(x)”. The Chinese word corresponding to “for” is “dui4”. The association with dui4 is “concentrating on”.

This last remark hints at a very important aspect, namely that a single element of a set is focused upon. In Chinese the statement “dui4 ren4 yi4 x P(x)” is slightly preferred over “dui4 sou3 you3 x P(x)”. The SKO-link was introduced with meaning “informationally dependent on”. A SKO-loop then can be read as “something informationally dependent only on itself”. This can be interpreted as “something arbitrarily considered”. Hence the word graph consisting of one token and a single SKO-loop can be named ANY. We take this as our starting point for finding word graphs for “each”, “every” and “all”.

The single element aspect comes forward in “every” with the meaning “each single”. In “each”, it comes forward in “regarded separately”. Here, however, there is the extra remark that “every one of *two or more* things” is part of the meaning of “each”. The entry for “every” also mentions “all possible”, meaning that there may be more elements. So whereas “any” focuses on the single element, “every” focuses on the single element *as part of a set*. This means that we can take the word graph



for the word “every”. Note the occurrence of the word graph for “any” in this graph, that can therefore be uttered as “any of (a) set”, which is synonym with “every”.

Now we can extend this graph to obtain the word graph for “each”:

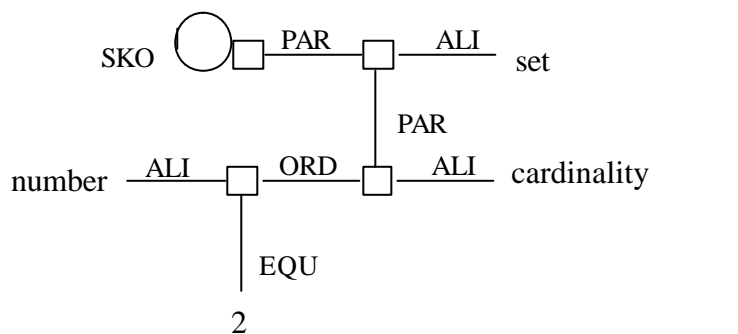

Note the occurrence of the word graph for “every” and the extension that can be uttered as “with cardinality greater than 2”.

In the meanings given for the Chinese words the single element aspect comes forward in “ge4ge4”, via the phrase “one by one”, and in “mei3ge4”, via “per”. The given entries suggest that the words “ge4ge4” and “mei3ge4” are closer in meaning than is expressed by the given word graphs. However, also in English the words “each” and “every” are not always distinguished very precisely, as can be seen from phrases like

“each and every”. In mathematics we can speak of “every element of a set of one element”, but “each element of a set of one element” is subtle less precise.

We are left with the word “all”. There were three entries given. The focus in all three meanings is on the *totality*. This brings us to the ontology of Kant. Under the heading “Quantity” he gives “unity”, “plurality” and “totality”. The first two express the element aspect and the set aspect. The third notion expresses the concept of “whole”. In language we see that we can speak of “all butter” as well as of “all dogs”. In both cases the totality aspect prevails. In a way the word “all” clearly differs from the three other words. This means that the use of the SKO-loop for describing the word “all” is put in doubt.

Consider expressions like “half the butter” or “almost all butter” or “hardly any butter”. What is described in these expressions are instantiations of the totality. For this reason we could consider the following graph:

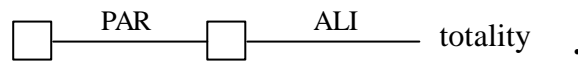

Thus “totality” is seen as an attribute of something, that can assume different values, one of which is “all”. We then have the word graph

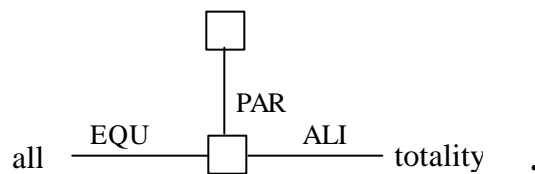

As “all butter” is expressed in Chinese as “suo3 you3 de huang2 you2” but not as “dou1 huang2 you2”, this graph could also be given as the word graph for “suo3 you3” in the form

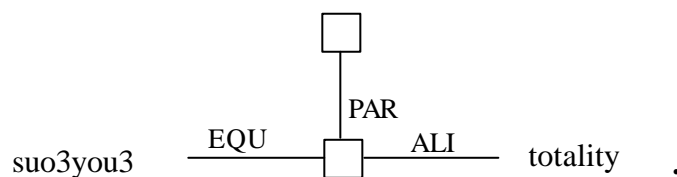

The word “de” then corresponds to the PAR-link, as we have already seen before. We will discuss “dou1” in the next section. Note that “dou1” cannot be used for quantifying mass words.

6.2 Uttering the word “dou1”

As we will see in Section 7 the various ways to utter a sentence graph are controlled by the rules of the grammar that is assumed to be valid for the language. In [Hoede &

Zhang, 2001b] we discussed a grammar derived from the syntactic word graphs. This presupposes that the type of word is known. However, it turns out that for certain words, like the Chinese word “dou1”, there is disagreement on the type of that word. In a paper of Cheng [Cheng, 1995] on “dou1” quantification a discussion about the possible occurrence in a sentence can be found.

In this paper we focus on uttering a sentence graph. This means that we choose to focus on sentence graphs containing the word “dou1”. In principle the possible utterings of such a sentence graph give all possible occurrences of the word “dou1”. However, we do not have rules for uttering such a sentence graph yet. We therefore studied the sentence graphs of several of the sentences mentioned by Cheng, in order to investigate the possibilities for uttering.

Note that this approach differs methodologically from that used by Cheng and others. They investigate certain sentences and partition them into the class of grammatically correct and the class of grammatically incorrect sentences. Then a discussion is held about similarity of sentences in the sense that “dou1” can or cannot occur in the same way as other words do. Cheng comes to the conclusion that “dou1” is a “nonmovable adverb”. However, in Section 6.1 “dou1” was seen as having a word graph like

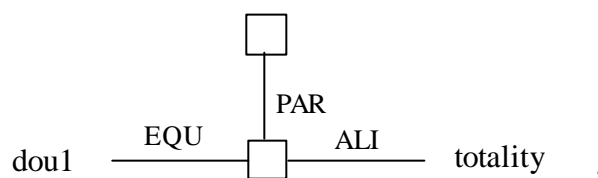

This is an *adword*, because of the PAR-link. But to what type of word does it attach? As we discussed in Section 6.1 the totality either describes an aspect of a set or of an object. In both cases we do NOT have attachment to a verb! An essential remark in Cheng’s paper can be found in her example (2) that reads (she does not give numbers 1, 2, 3 or 4)

Tamen	dou	hen	xihuan	wo	.
They	all	very	like	I	

She remarks that “dou” here quantifies a noun phrase NP to its left and that *the NP must have plural interpretation*. But that means, mathematically, that the NP must describe a set. We decided to focus on this aspect and investigate how various sentence patterns allowed the uttering of “dou” for the other example sentences in Section 2.1 of her paper.

Before doing this let us remark that statements like “tamen”, they, or “neixie xuesheng”, those students, have a plural interpretation. If the word “tamen” is used, in principle *all* the people described are meant. The same holds for “neixie xuesheng”. Any statement about “those students” in principle includes all of them. We may therefore consider the example sentences without the word “dou” to see whether the meaning of the sentence is essentially changed. If not the word “dou” is only used to express emphasis!

We now go through the example sentences.

(1) tamen dou lai-le
 they all come-ASP
 “They all come.”

(ASP, for aspect, is referring to the function of the word “le”)

The sentence graph, apart from the tense, is

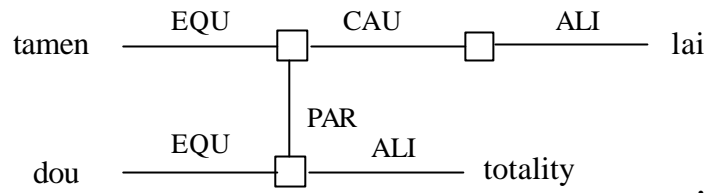

The word graph for “dou” has been indicated here completely. In the following examples we will just link a black token to the word with plural interpretation. For this example sentence we would give the sentence graph

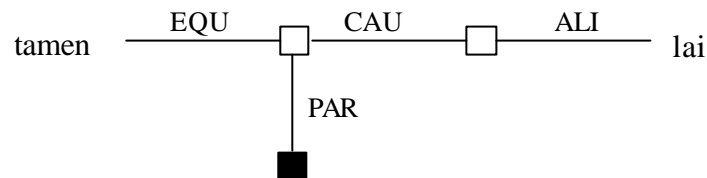

We see that “dou” is an adword of “tamen” and *not* an adword of “lai”. This speaks against the assumption that “dou” is an adverb. Not that the sentence “tamen lai-le” has essentially the same meaning. The word “dou” could have been omitted, and therewith the black token in the sentence graph.

Example sentence 2 involves a transitive verb.

(2) tamen dou hen xihuan wo
 they all very like I
 “They all like me” .

There is no essential difference with example sentence (1) as the word “dou” quantifies “tamen”, the only word with plural interpretation, and moreover it mainly functions as giving emphasis. It could have been left out here.

We now also consider this simple SVO-pattern in a sentence where both subject and object have plural interpretation.

(3) tamen dou xihuan neixie xuesheng
 they all like those student.

Here both “tamen” and “neixie xuesheng” have plural interpretation. Yet the word “dou” can only be used once, namely quantifying the subject “tamen”.

The sentence graph is:

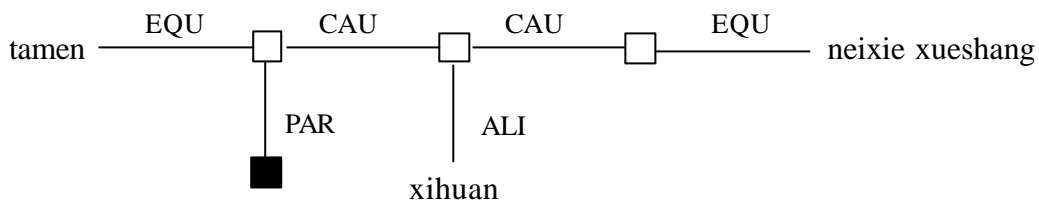

Again “dou” is used for emphasis. However, it cannot be an adword for “neixie xuesheng”. So, as an utterance rule, we can say that “dou” can only be used, to express emphasis, for a subject with plural interpretation.

Suppose we would like to say: “they like all those students”. In Chinese we might say “tamen xihuan suo you de neixie xuesheng”, but this is considered to be as good as simply “tamen xihuan neixie xuesheng”. This again shows that words with plural interpretation do not have to be combined with words expressing universal quantification.

Next to the emphasis function “dou” seems to have a reference function similar to that of determiners and pronouns.

(4) zhexie xuesheng wo dou xihuan

these student I all like

“I like all of these students”.

Here “dou” is used as a reference word. The word “zhexie” already describes the plurality aspect. Replacing “dou” by “tamen” we have a similar sentence

(5) zhexie xuesheng wo xihuan tamen

“These student I like they”,

where the only difference is that the referring word “tamen” now follows the verb.

Also in the case of an embedded sentence we encounter the reference function of “dou”. Cheng gives the sentence

(6) neixie xuesheng wo xiangxin Lisi dou xihuan

those students I believe Lisi all xihuan

“All those students I believe Lisi likes them”.

Already from the third line in which, in the translation, “them” is used for the reference, the reference function is clear. Also, from the translation, the direct adword function with respect to “those students” is evident.

Three other patterns will be considered.

First there is the pattern of combination of “dou” and negation. Let us consider the example sentence

(7) neixie ren v_i meiyou v_j kan-guo neiben shu

those person not read-ASP that book ,

where “dou” can be inserted on two places. We consider the sentence graph in both cases, without attention to the tense aspects.

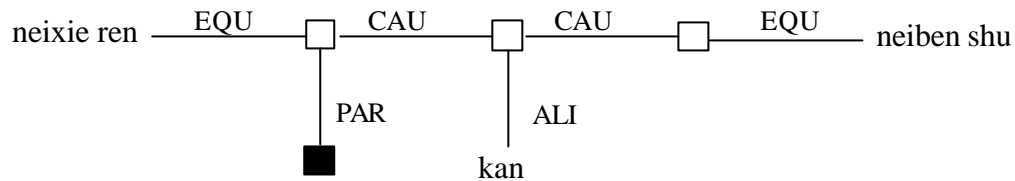

This graph gives the basic structure without the NEG-frame : those people read that book. The NEG-frame can now be inserted in two ways, either around

or around the whole graph (j).

The meaning is then respectively

(i) All of those people did not read that book

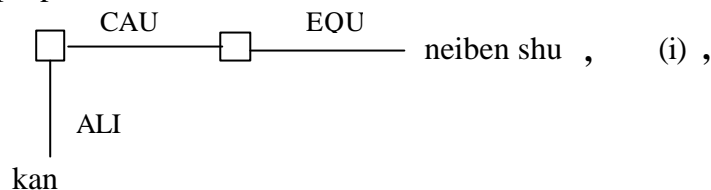

(j) Not all of those people read that book.

Finally there are the BA-pattern and the BEI-pattern.

A sentence in SVO-form may be uttered in SOV-form, but then the auxiliary word BA has to be used.

(8) a. neixie xuesheng dou ba neiben shu mai-le
 those student all BA that book sell-ASP
 “All those students sold that book.”

Here the subject has plural interpretation and “neixie xuesheng” can be followed by “dou”, as emphasis.

In the sentence:

(8) b. zhangsan ba neixie shu dou mai-le
 zhangsan BA those book all sell-ASP
 “Zhangsan sold all those books”,

the object can be quantified by “dou”, by uttering “dou” after neixie shu.

In case both S and O have plural interpretation, again only one can be emphasized by “dou”.

In abstract sense we consider the following sentence graph:

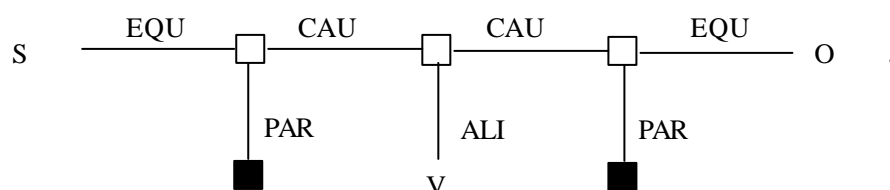

We have assumed that both S and O have a plural interpretation and that there are two adwords “dou” attached to them. The uttering of this sentence graph is “All S V all O”. However, the essential meaning could also be uttered in “S V O”, because of the plural aspect of both S and O.

In Chinese we can say

“S dou BA O V”, or “S BA O dou V”.

This is the uttering rule for “dou” in case of a sentence with BA-pattern.

Another, often used, pattern is the BEI-pattern, usually used for expressing the completed tense. Again Cheng gives two example sentences.

(9) a. neixie xiaohai dou bei Lisi gifu-guo
those children all BEI Lisi bully-ASP

“Those children were bullied by Lisi.”

Here the uttering of “dou” is directly after neixie xiaohai, that has plural interpretation, and “dou” can occur only here. When uttered after “Lisi” “dou” would have a reference function, but uttering it here is not considered.

(9) b. zhangsan bei zhexie laoshi dou ma-le
zhangsan BEI these teacher all scold-ASP

“Zhangsan has been scolded by all these teachers.”

Again the uttering of “dou” is directly after “zhexie laoshi”, that has plural interpretation, and can occur only here.

Let us consider the abstract situation again, in which both S and O have plural interpretation.

The BEI-pattern turns the sentence “S V O” into the sentence “O BEI S V”. Uttering “dou” is now only possible in a sentence with one of S and O. In case both have plural interpretation both “O dou BEI S V” and “O BEI S dou V” are allowed. In “neixie xiaohai bei zhexie laoshi ma-lethose (children BEI these teacher scold-ASP)”, we can utter “dou”, as emphasis, after “neixie xiaohai” or after “zhexie laoshi”.

From the knowledge graph point of view we see that “dou” is considered to be an adword attached to a noun with plural interpretation. It has two functions, one as quantifier, although that is not absolutely necessary. In that case the word puts emphasis on the noun. The other function is that of a reference word. It is therefore remarkable that in Cheng’s paper “dou” is considered to be an adverb. To put it in the words of Cheng, we think that “dou” is a head taking a noun as complement. In Section 3.2.1 Cheng states that “dou” falls within the class of *nonmovable adverbs*, like “yijing”, already. She gives example sentences

(30) a. Zhangsan yijing hui jia-le
Zhangsan already return home ASP

“Zhangsan has already return home.”

b. * Yijing zhangsan hui jia-le .

Sentence b is not correct. “Yijing” cannot “move” from after the subject to the front of the sentence. In the example

(20) a. jintian wo bu shufu
 today I not comfortable
 “Today I don’t feel well.”

b. wo jintian bu shufu

We see that “jintian” can be moved to the front. We quote:

“ Dou is not a time adverb or attitude adverb, and it cannot appear before the subject. It is thus not a movable object. Dou falls within the class of nonmovable adverbs like yijing ‘already’ .”

This conclusion is mainly based on grounds concerning the *distribution* of adverbs in uttering. However, let us consider the two time adverbs “already” and “today”. One is nonmovable and the other one is. From the point of view of knowledge graph theory the difference should come forward in the sentence graph. We consider the two sentences “he returned today” and “he returned already”. The adverbs attach to the verb, by definition.

So in both sentences we have the basic structure

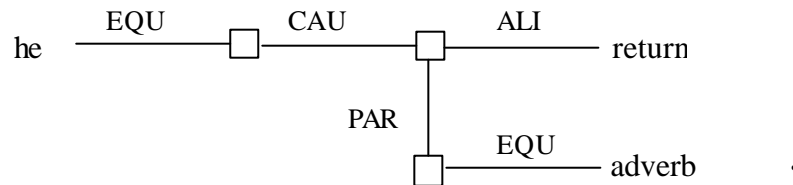

The difference must lie in the word graphs, the semantics, of the two adverbs. For “already” we have:

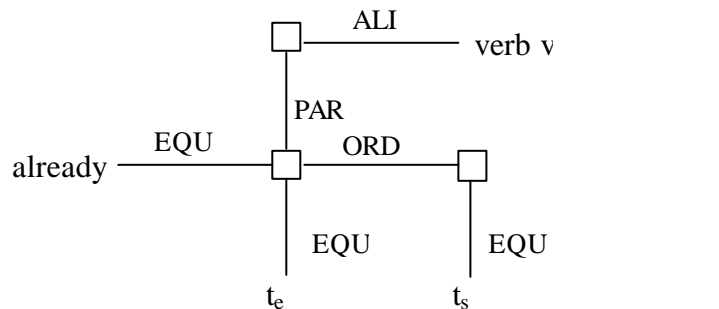

The act, described by the verb v, has finished at t_e , before the uttering time t_s of the sentence.

For “today” the graph is:

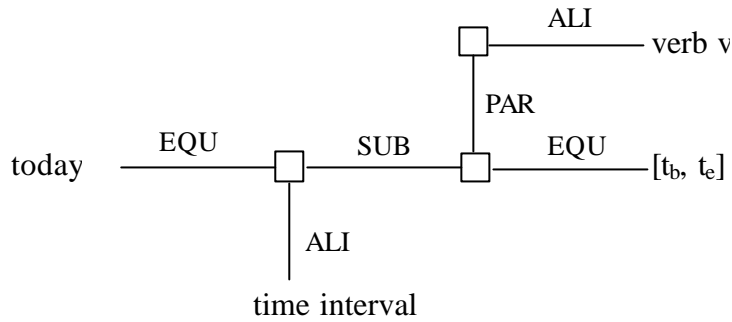

The difference between “already” and “today” is considerable, when we focus on the explicit description of the time aspects. There is a considerable semantic difference, although both graphs attach to the verb *v*, i.e., both words are adverbs.

This brings forward an important aspect of uttering. Although we are dealing with two time adverbs here, the structure of the sentence graph seems to have profound influence on uttering, in Chinese. So also for “*dou*” we may expect that its meaning plays an important role, i.e., the way it occurs in the sentence graph does, as “the structure is the meaning”. That “*dou*” has the distributional properties of a nonmovable adverb like “*yijing*” seems to be no reason to consider it to be a nonmovable adverb, like Cheng does.

7 Uttering and Grammar

Having considered the uttering of very specific types of words, we now want to start a more general discussion on uttering a sentence graph.

Let there be a set of utterings for a sentence graph. Each uttering should be grammatically correct. It must have a parse tree based on the grammar assumed to be valid. So there are as many parse trees for the one given sentence graph as there are utterings. A specific parse tree reflects an utterance path. We have seen that a sentence can be seen to consist of chunks. These chunks are on the one hand parts of the parse tree and on the other hand parts of the sentence graph. The following figure schematically describes the relationships between parse tree, utterance path, chunks and sentence graph.

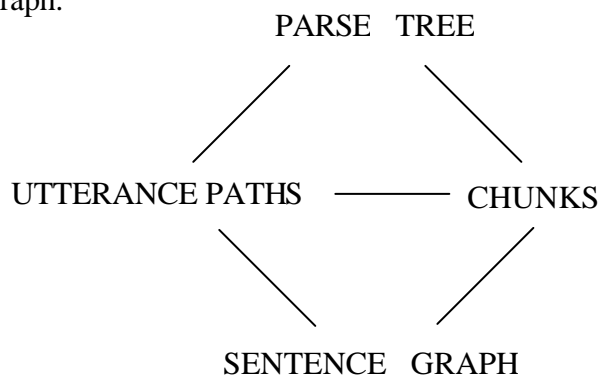

Our goal is to describe how a sentence graph can be uttered in a grammatically correct way. For this we have to indicate which words, or word groups, i.e. phrases, may follow each other. This typically is ruled by the syntax of a language and therefore the possible juxtaposition of two words is ruled by the production rules of the grammar.

7.1 An introductory example

We will choose, as an example, the grammar for English derived in [Hoede & Zhang, 2001b] from the way syntactic word graphs can combine. Let us, again, consider the uttering of the words “the” and “dog”, a determiner and a noun. In a sentence graph we might find the subgraph

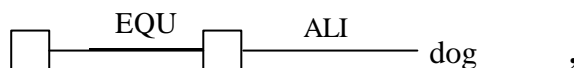

where the EQU-link is the word graph for “the”.

The syntactic graph of a determiner is



Let us now consider the production rule

$$6. N ? \text{ det } N ,$$

expressing that a noun can be replaced by a determiner followed by the noun. The important aspect is that the rule does NOT state $N ? N \text{ det}$.

For this reason the subgraph can be uttered as “the dog”, but not as “dog the”. This is coming forward from the syntactic graph, from the direction of the SKO-arc. The word “the” might be given the semantic word graph:

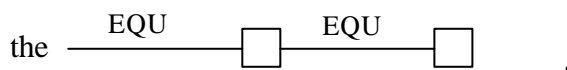

Rule 6 : $N ? \text{ det } N$ gives us a possible uttering rule for a determiner attached to a noun. Whenever occurring in a sentence graph the allowed order can be indicated by an arc from the determiner to the noun. Note that this arc has no label, it merely expresses the possible order of the words in juxtaposition. Deleting the links of the sentence graph gives thus a graph containing only such “uttering arcs”, which might therefore be called an “uttering graph”.

Before systematically investigating the 18 production rules of our chosen grammar, we want to investigate rule 5:

$$5. N ? \text{ adj } N .$$

Here too an ordering for uttering an adjective and a noun is forced. Suppose we have

the words “small” and “dog”, then we can say “small dog” and NOT “dog small”.

A complication comes in when rule 5 is applied twice:

N ? adj N ? adj adj N .

This implies that two adjectives can be uttered in juxtaposition before uttering the noun. Let us consider the words “poor”, “small” and “dog”. We may utter “poor small dog” as well as “small poor dog”. In a sentence graph we might find the subgraph:

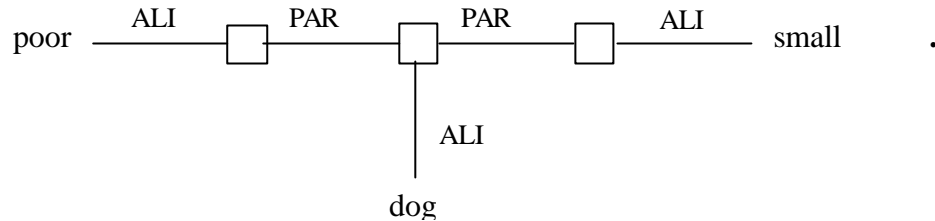

Syntactically we have:

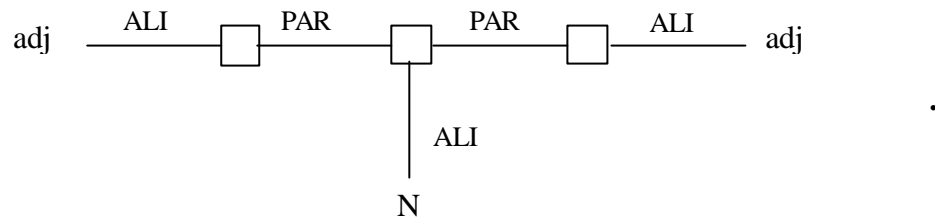

The uttering arcs are corresponding to the PAR-arcs towards the noun. The possibility of generating a second adjective by rule 5 implies that for the two adjectives there should be uttering arcs from one adjective to the other. The part of the uttering graph corresponding to the considered subgraph is now

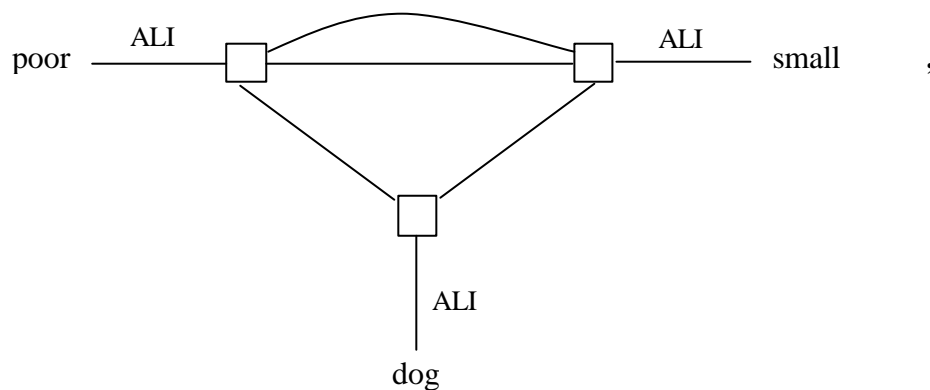

where we have maintained the typifying ALI-arcs for reasons of clarity.

Rules 5 and 6 can be combined, but only in the following order:

N ? det N ? det adj N .

This implies that there can be an uttering arc from the determiner to the adjective, but not the other way around.

Let us now consider the phrase “the poor small dog”, and let us give both the part of the sentence graph and its uttering graph. The semantic graph is

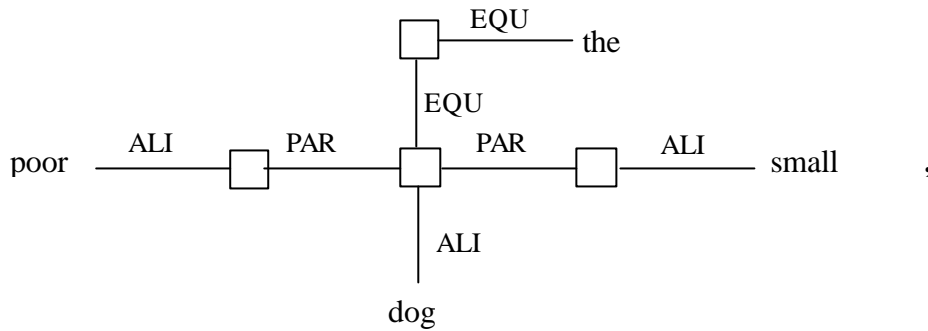

and its uttering graph is

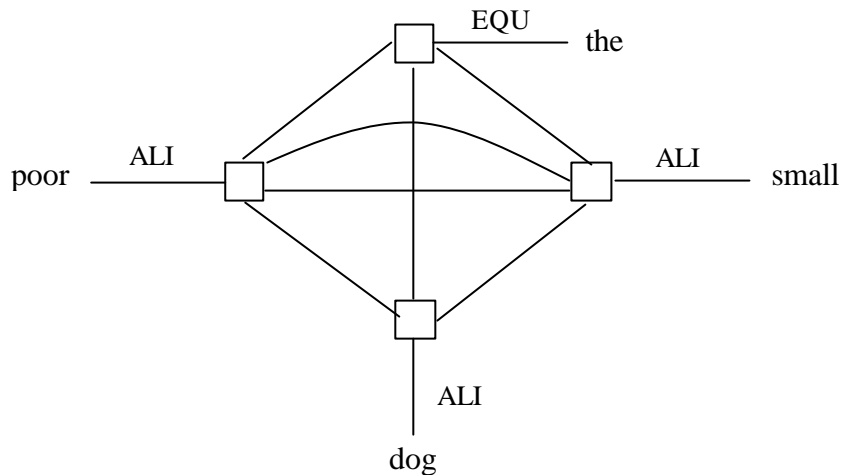

The arc from the determiner to the noun has been discussed. The arcs from the determiner to the two adjectives stem from the combination possibility for rules 5 and 6.

To finish this introductory example let us see how the semantic graph can be uttered. All four words have to be uttered. As there are only outgoing arcs for the determiner in the uttering graph, “the” must be uttered first. As there are only incoming arcs for the noun, “dog” must be uttered last. The two adjectives “poor” and “small” can be uttered between “the” and “dog” in both possible orderings. Note that the two “uttering paths” in the uttering graph are Hamilton paths as all vertices are contained in the paths. In fact the number of possible uttering paths is equal to the number of Hamilton paths in the uttering graph. The uttering graph for the sentence graph given in Figure 4, for the Serbocroatian grammar (!), has 24 Hamilton paths and would look like

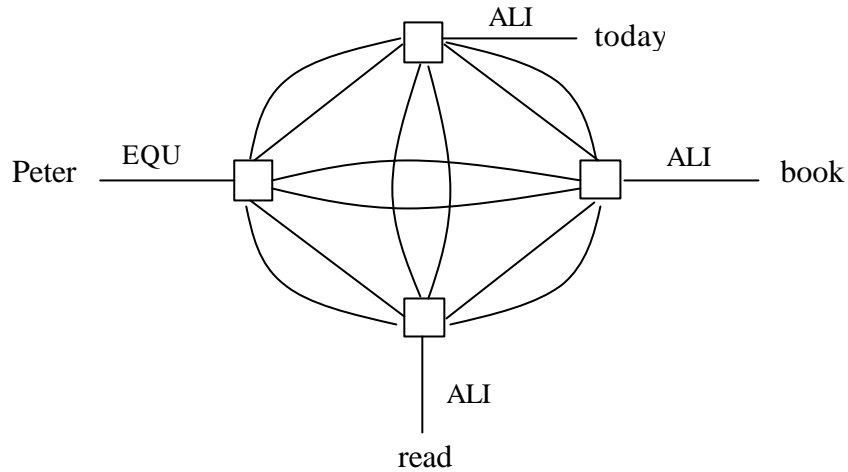

For the imaginary language X, only uttering was possible. The uttering graph looks like

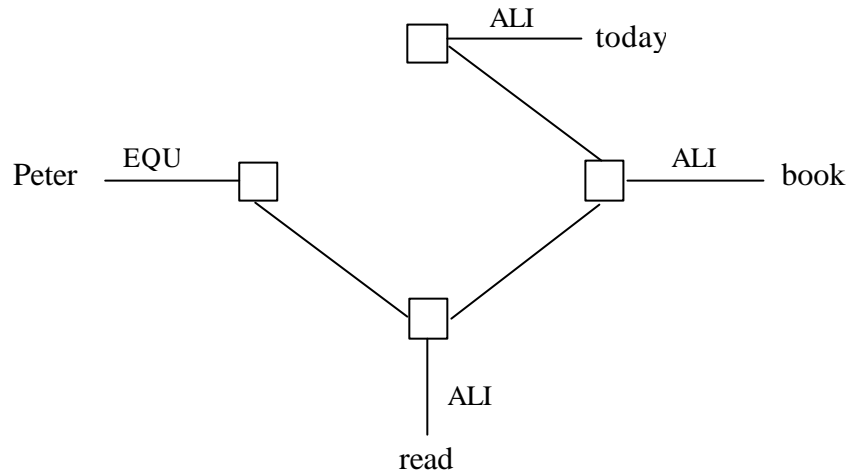

and has one Hamilton path.

7.2 Uttering rules from production rules

Let us recall the grammar described in [Hoede & Zhang, 2001b]. We formed the following English grammar rules:

1. S ? NP VP
2. NP ? PN
3. NP ? N
4. N ? N N
5. N ? adj N
6. N ? det N
7. AP ? prep N

8. N ? num N
9. N ? PN N
10. AP ? V N
11. VP ? V
12. VP ? V N
13. VP ? V PN
14. V ? V V
15. V ? adv V
16. V ? V adv
17. V ? V AP
18. adj ? adv adj .

Note that this is just one of many grammars that may be considered. Our reasoning will be restricted by this choice.

The rules 2, 3 and 11 concern simple instantiation and therefore do not infer a condition on the order of uttering words or phrases. This leaves 15 rules to be considered.

7.2.1 Rules involving word types only

We start by considering the rules in which a noun N is involved, and no phrases. These rules are rules 4, 5, 6, 8, 9. It was already pointed out that there is a difference between the role of grammar rules in traditional parsing and the role they play in uttering a sentence graph. Given a sentence, the problem is to find a parse tree and the order of applying rules is to be determined. However, when applying rules in arbitrary order we might generate phrases or sentences that are not correct. So only certain orderings of rules are possible. Rule 4. N ? N N generates a juxtaposition of two nouns. The second noun cannot be taken to generate for example an adjective, by rule 5, that would then stand between the two nouns. We can say “severe thunder storm” but not “thunder severe storm”. An important other example is the combination of rule 5 and rule 6, as “the small dog” is a possible uttering, but “small the dog” is not. We will use our own knowledge to decide on the possibility of utterings.

Let us now consider the phrase

“The three mean tall men”.

We know that the determiner “the” has to be uttered first, so the generation of this phrase should start with rule 6. Then the numeral must be uttered, which forces us to use rule 8. The two adjectives can now be generated by applying rule 5 twice. Their order is irrelevant. This now means that for uttering a part of a sentence graph in which a noun occurs, there are uttering orderings that can be indicated as:

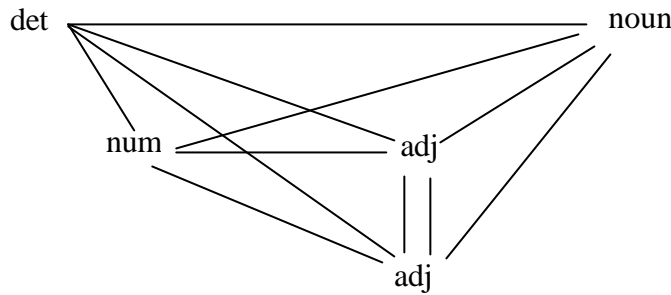

These arcs will be called uttering arcs, *u-arcs*. Rule 9, in which a PN is generated before the noun is similar to rule 6. The schema describes the uttering rules for parts of the sentence in which the five rules must be used when parsing the uttered phrase. Rule 18 puts an adverb in front of an adjective, as e.g. in “very big”. For the uttering ordering expressed in the schema, this means that adv should be added and with arcs to adj, while from det and num there should be arcs to adv. Note that there cannot be an *u-arc* from adv to N. Also note that rule 18 can be repeated as we can say “very very big”. Remaining are rules 14, 15, and 16 involving V. Rules 15 and 16 describe that an adverb attached to a verb can be generated in both orderings. However, given a sentence graph, both cannot be used. For example we may say “he just came”, but not “he came just”, while we can say “he worked hard”, but not “he hard worked”. So, in principle for uttering a verb-adverb attachment we need more information and cannot give a general uttering rule here.

Rule 1. $V ? V V$ is particularly interesting because of what we discussed in Section 5. The first V of $V V$ usually is an auxiliary verb, which in the sentence graph is represented by a frame. The sentence “He must go” has sentence graph

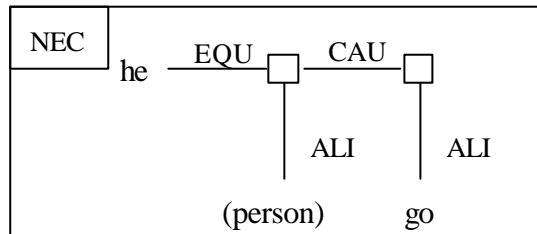

The frame expresses the auxiliary verb “must”. We have to start uttering with the PN “he”, because English is an SVO-language, but then immediately the auxiliary verb, the frame, must be uttered. Then the content of the frame must be uttered, which in this case is just the word “go”.

7.2.2 Rules involving phrases

We are left with rules 1, 7, 10, 12, 13 and 17. Let us begin with the rules that involve the adverbial phrase AP. Rule 7 shows that such a phrase may start with a preposition. We

might therefore speak of prepositional phrase too, but prefer to use the more general notation AP.

In a sentence graph an AP starting with a preposition can be determined by that preposition. Note that the preposition, a link word, was one of the chunk indicators in [Hoede & Zhang, 2001b].

Rule 7: AP ? prep N generates a preposition before a noun. This noun could be extended to a noun phrase, as considered in Section 7.2.1, but this means that there should then be u-arcs from the preposition to all the word types that can be uttered before the noun in the noun phrase. Rule 10 generates the order V N as an AP. Rule 17 puts an AP behind the verb V. There are two conclusions here. An uttering, like “drinking coffee” may occur as an AP bringing two verbs in juxtaposition. This is just a consequence of the fact that we took rule 10 into our grammar. Rule 17 restricts the position, in an uttering, of an AP. The AP should be uttered after the verb has been uttered. Repetition of rule 17 is possible and, here, two APs can be uttered after each other, in any order.

The verb phrase starts with a verb, as is determined by rules 12 and 13. Rule 12: VP ? V N shows that there should be a u-arc from the V to the noun N, and to all that can be generated before that noun. Finally, rule 1 reflects the SVO-language and we have already discussed how to determine the NP. Determine the verb and, by the incoming CAU-arc, determine the noun in the NP, then add a u-arc from the end of the noun phrase (which is the noun) to the verb.

These are the u-arcs consistent with the considered grammar. We will now apply our findings to the extended example of Section 3.

7.3 Uttering paths for the extended example

We have discussed our representation of the uttering graph. We delete all links between tokens but maintain the EQU-arcs and ALI-arcs in order to indicate the words. For frame words like “with” and “in” we use auxiliary tokens to avoid too complicated graphs.

There are two ways to utter “the mean tall man” and “the small poor dog” parts. The APs can be uttered in only one way but in two possible orderings. The $2 \times 2 \times 2 = 8$ possible utterings correspond to the 8 Hamilton paths of the uttering graph. The 8 possible sentences are

1. The mean tall man hit in the garden with a very big stick the poor small dog.
2. The tall mean man hit in the garden with a very big stick the poor small dog.
3. The mean tall man hit in the garden with a very big stick the small poor dog.
4. The tall mean man hit in the garden with a very big stick the small poor dog.

5. The mean tall man hit with a very big stick in the garden the poor small dog.

6. The tall mean man hit with a very big stick in the garden the poor small dog.

7. The mean tall man hit with a very big stick in the garden the small poor dog.

8. The tall mean man hit with a very big stick in the garden the small poor dog.

Sentences 5, 6, 7, 8 are as 1, 2, 3, 4, but with interchange of the APs “in the garden” and “with a very big stick”.

Figure 9 gives the uttering graph of the sentence graph. The reader may read off the given 8 sentences by following the 8 different Hamilton paths.

Note that the APs could be uttered after “the poor small dog”, allowing the use of commas. This would again increase the number of possible utterings.

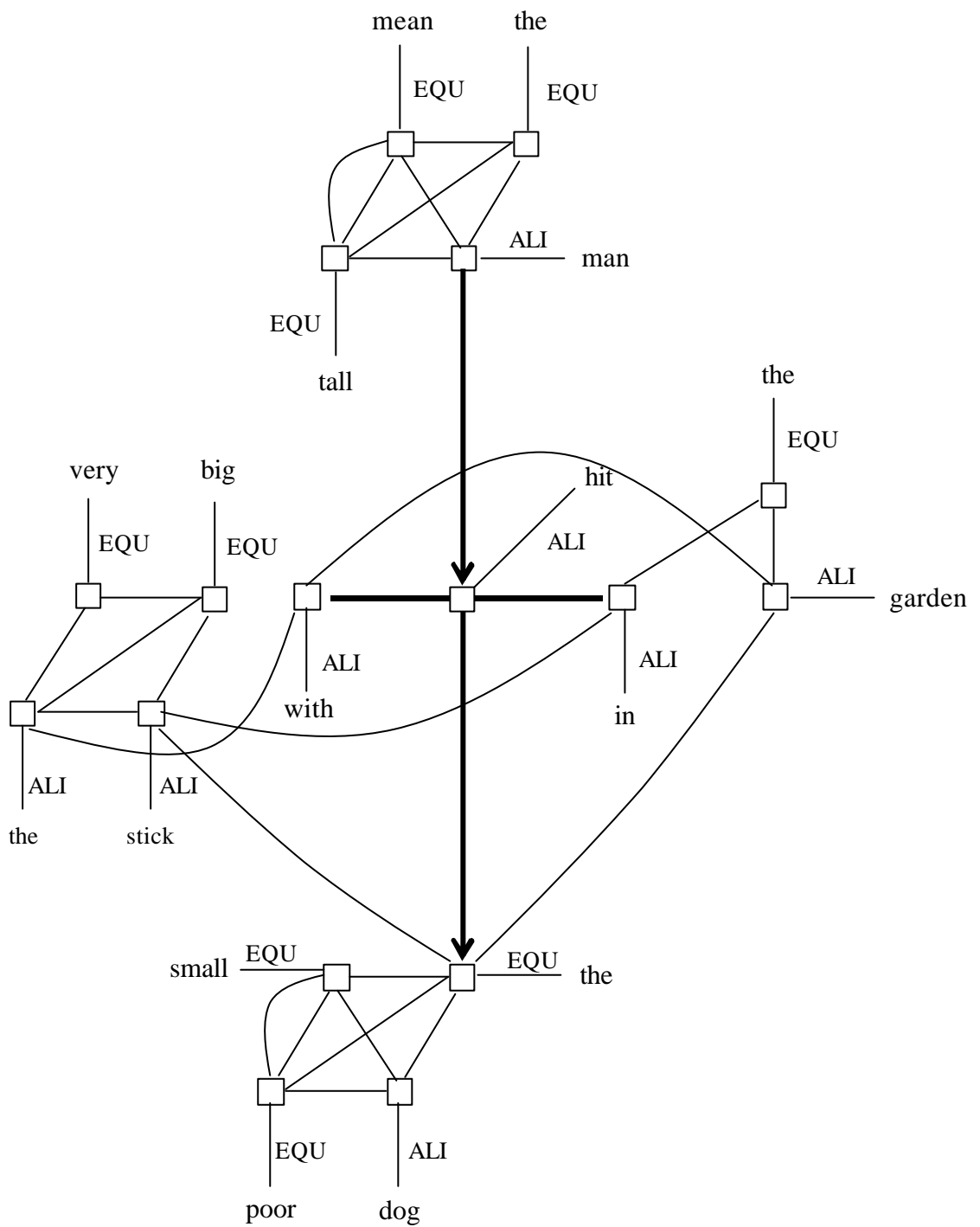

Figure 9. Uttering graph for the extended example.

References

- [Allen, 1984] R. E. Allen, *The Pocket OXFORD Dictionary*, Seventh Edition, Oxford University Press, New York, 1984.
- [Berg, 1993] H. van den Berg, *Knowledge Graphs and Logic: One of Two Kinds*. Ph.D. thesis, University of Twente, Enschede, The Netherlands, ISBN90-9006360-9, 1993.
- [Ce, 1988] C. Ce, *A Modern Chinese-English Dictionary*, Foreign Language Teaching and Research Press, 1988.
- [Cheng, 1995] L. L. Cheng, On Dou-Quantification, *Journal of East Asian Linguistics*, 4: 197-234, 1995.
- [Hoede & Li, 1996] C. Hoede and X. Li, *Word Graphs: The First Set*. In: *Conceptual Structures: Knowledge Representation as Interlingua*, Aux. Proc. of the Fourth International Conf. on Conceptual Structures (Eds. P.W.Eklund, G.Ellis and G.Mann), Bondi Beach, Sydney, Australia, 81-93, 1996.
- [Hoede & Zhang, 2001a] C. Hoede and L. Zhang, *Word Graphs: The Third Set*. In: *Conceptual Structures: Broadening the Base*, Proc. of the 9th International Conf. on Conceptual Structures (Eds. H.S.Delugach and G.Stumme), CA, USA, Lecture Notes in Artificial Intelligence no.2120, 15-28, 2001.
- [Hoede & Zhang, 2001b] C. Hoede and L. Zhang, *Structural Parsing*. In: *Conceptual Structures: Extracting and Representing Semantics*, Aux. Proc. of the 9th International Conf. on Conceptual Structures (Ed. G.W.Mineau), CA, USA, 75-88, 2001.
- [Radford, 1988] A. Radford, *Transformational Grammar: A First Course*. Cambridge University Press, Cambridge, 1988.